

# Bag / sock filter vessel

## Technical drawing ( DYS03 & DYS04 )

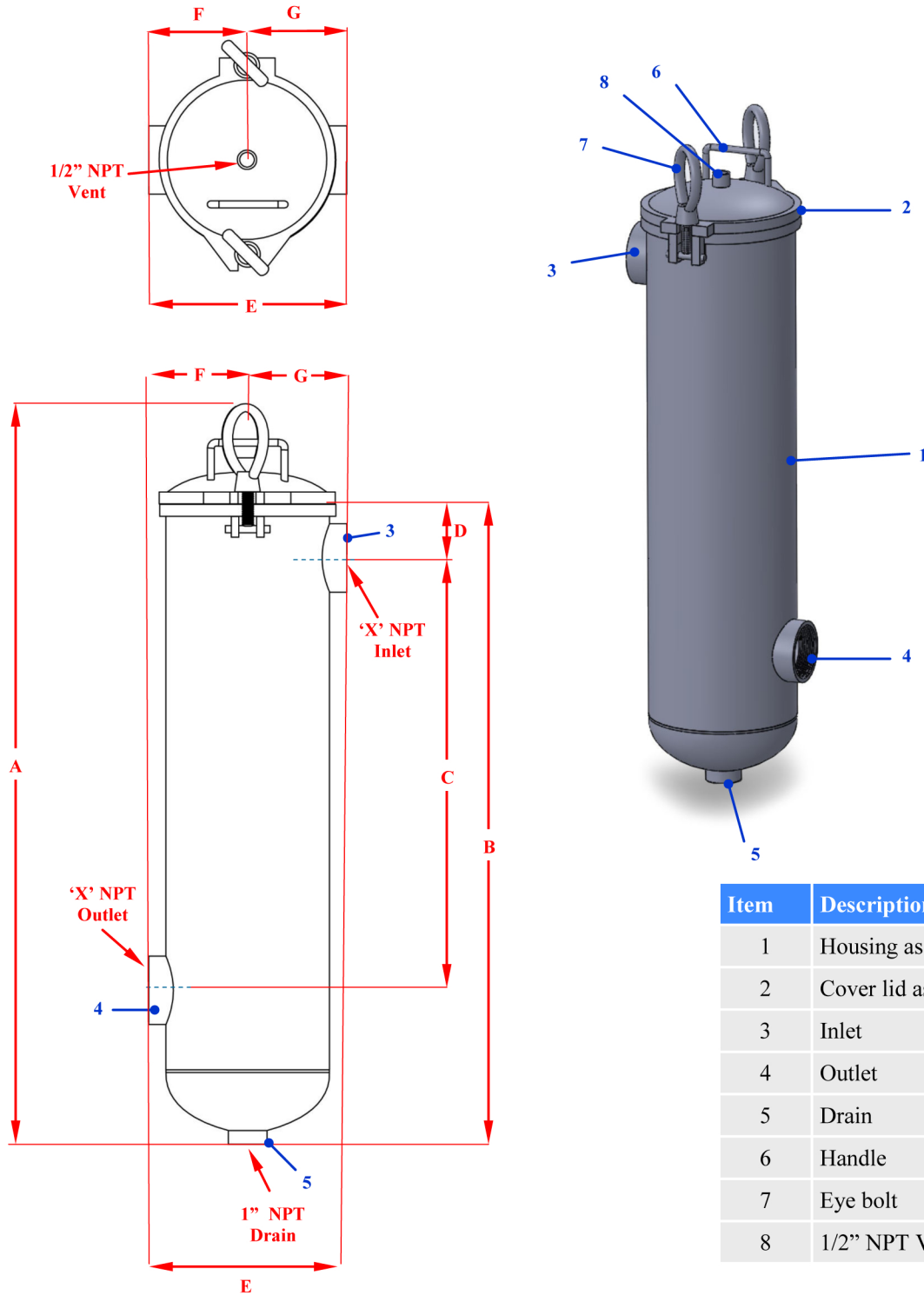

Item	Description
1	Housing assemble
2	Cover lid assemble
3	Inlet
4	Outlet
5	Drain
6	Handle
7	Eye bolt
8	1/2" NPT Vent

DYS03 (15 gallon per min)							
X	A	B	C	D	E	F	G
1	16 7/16	13 7/16	5 3/8	1 13/16	6	3	3
2	17 1/4	14 1/4	5 3/8	2 1/2	6 3/8	3 1/8	3 1/4

DYS04 (30 gallon per min)							
X	A	B	C	D	E	F	G
1	21 15/16	18 15/16	10 5/8	1 13/16	6	3	3
2	22 3/4	19 3/4	10 5/8	2 1/2	6 3/8	3 1/8	3 1/4